

MODEL  
IWC46

WINE CHILLER  
45 BOTTLE

INALT<sup>®</sup>

CLASSIQUE

V 1.3

USER MANUAL

**Residentia Group Pty Ltd**

ACN 600 546 656

—

Head Office.

165 Barkly Avenue, Burnley

VIC Australia 3121

—

Support.

1300 11 4357

support@residentiagroup.com.au

—

Online.

www.residentia.group

www.inalto.house

---

Congratulations on purchasing your new wine fridge. The InAlto brand is proudly distributed within Australia by Residentia Group Pty Ltd.

Please refer to the warranty card at the rear of this manual for information regarding your product's parts and labour warranty, or visit us online at [www.residentia.group](http://www.residentia.group)

At Residentia Group, we are customer obsessed and our Support Team are there to ensure you get the most out of your appliance. Should you want to learn more about recommended temperatures, the various features of your wine fridge, and importantly taking care of your appliance when cleaning, our Support Team are here to help. You can use our online Support Centre at anytime by visiting <http://support.residentiagroup.com.au>, or you can contact us via calling us on 1300 11 HELP (4357).

It is important that you read through the following use and care manual thoroughly to familiarise yourself with the installation and operation requirements of your appliance to ensure optimum performance.

Again, thank you for choosing an InAlto appliance and we look forward to being of service to you.

Kind Regards,  
The Residentia Team



---

**Contents**

---

**02  
Welcome**

---

**04  
General  
Safety**

---

**06  
Product  
Overview**

---

**07  
Getting  
Started**

---

**07  
Installation**

---

**08  
Operation**

---

**11  
Door  
Reversal**

---

**14  
Maintenance  
& Care**

---

**15  
Troubleshooting**

---

**16  
Specifications**

---

**17  
Purchase  
Details**

---

**18  
Warranty**

---

# General Safety

## IMPORTANT SAFETY INSTRUCTIONS READ CAREFULLY AND KEEP FOR FUTURE REFERENCE

Read this manual thoroughly before first use, even if you are familiar with this type of product. The safety precautions enclosed herein reduce the risk of fire, electric shock and injury when correctly adhered to. Make sure you understand all instructions and warnings.

Keep the manual in a safe place for future reference, along with the completed warranty card and purchase receipt. If you sell or transfer ownership of this product, pass on these instructions to the new owner.

Always follow basic safety precautions and accident prevention measures when using an electrical appliance, including the following:

**WARNING:** This is a wine chiller, this is NOT to be used to preserve or store fresh food or consumables.

A wine chiller is designed for the storage of bottles at a set temperature that is particularly suitable for wine. The temperature maintained in this wine chiller is too high for safe storage of perishable foods.

### Electrical Safety

- **Voltage:** Before connecting and turning on the wine chiller, ensure the electrical voltage and circuit frequency correspond to that indicated on the appliance rating label.
- **Earthing:** This wine chiller should be properly earthed for your safety. The power cord of this wine chiller is equipped with a three-prong plug for use in standard wall outlets to minimise the possibility of electrical shock. Do not modify the cord and/or plug provided with the appliance. Improper use of the earthed plug can result in the risk of electric shock.
- **Connection:** This wine chiller requires a standard 220-240 V AC 50Hz electrical outlet. Do not overload the electrical circuit.
- **Power cord:** Do not kink or damage the power cord; do not leave it exposed or dangling. Secure it at the back of the appliance so no one steps on or places anything on the cord or against it. Keep the cord out of reach of children. When moving the appliance, make sure not to damage the power cord.
- **Auxiliary Items:** Do not use an inverter, adaptor or extension cord with this wine chiller. If the cord is too short, have a qualified electrician install an outlet near the appliance. Use of an extension cord and an inverter can negatively affect the performance of the unit.
- **Protect from moisture:** To protect against the risk of electric shock, do not immerse the unit, cord or plug in water or spray it with any other liquid. Do not connect or disconnect the electric plug when your hands are wet. Turn the power switch off before removing the plug from the socket.
- **WARNING: Disconnect!** To reduce the risk of fire, electric shock or personal injury, always unplug the appliance from the socket when not in use, when moving and before cleaning or servicing. Never unplug the unit by pulling the power cord. Always grip the plug firmly and pull straight out from the power point.
- **Electrical work:** Any electrical work required for the installation of this appliance should be carried out by a qualified electrician.

### Usage Conditions and Restrictions

- **Domestic use only:** This wine chiller is intended for indoor household use only. It is not intended for commercial, industrial or outdoor use. It is not intended for use in a recreational vehicle.
- **Purpose:** Do not use this wine chiller for anything other than its intended purpose. Other uses are not recommended and may cause fire, electric shock or personal injury.
- **Attachments:** The use of attachments is not recommended by the appliance manufacturer and distributor as they may be hazardous.

- **Improper use:** Damage due to improper use, or repairs made by unqualified personnel will void your warranty. We assume no liability for any eventual damages caused by misuse of the product or noncompliance with these instructions.

#### General Safety Instructions Cont.

- **WARNING:** Do not use mechanical devices or other means to accelerate the defrosting process, other than those recommended by the manufacturer.
- **Usage restriction:** This wine chiller is not intended for use by persons (including children) with reduced physical, sensory or mental capabilities, or lack of experience and knowledge, unless they have been given supervision or instructions concerning use of the appliance by a person responsible for their safety.
- **Children:** Supervise young children to ensure they do not play with the appliance. Never allow children to operate, play with or crawl inside the wine chiller.
- **WARNING:** Do not use electrical appliances inside the wine chiller, unless they are of the type recommended by the manufacturer.
- **Explosive or flammable substances:** Do not store explosive substances such as aerosol cans with a flammable propellant in this wine chiller. Do not store or use petrol or any other flammable vapours and liquids in the vicinity of this or any other appliance. Do not use such substances for cleaning the wine chiller. The fumes can create a fire hazard or an explosion.
- **Damage:** Do not use the wine chiller if the power cord, plug or the wine chiller itself is damaged. If the cord is damaged, contact the after sales support line and have the cord replaced by qualified personnel in order to avoid a hazard.
- **WARNING:** Do not damage the refrigerant circuit.
- **Do not modify:** Do not attempt to alter or modify this wine chiller in any way.
- **Repair:** Do not attempt to repair or replace any part of your wine chiller unless it is specifically recommended in this manual. All other servicing should be referred to a qualified technician. Contact the after sales support line for advice.
- **WARNING:** Keep ventilation openings, in the wine chiller enclosure or in-built structure, clear of obstruction.



**CAUTION**  
RISK OF FIRE

This symbol alerts you to take care as this wine chiller contains a flammable refrigerant (isobutane) and insulation blowing gas (cyclopentane). Do not expose it to high heat, sparks and open flames.

The refrigerant isobutane (R600a) is contained within the refrigerant circuit of the appliance, a gas with a high level of environmental compatibility, which is nevertheless flammable. During transportation and installation of the wine chiller, ensure that none of the components of the refrigerant circuit become damaged.

**Never use a wine chiller with a damaged refrigerant circuit!** If the coolant circuit becomes damaged, avoid proximity to open fires and all types of heat sources. The room in which the wine chiller is located should be ventilated for a few minutes.

It is hazardous for anyone other than an authorised service person to service this wine chiller. In Queensland, the authorised service person **MUST** hold a Gas Work Authorisation for hydrocarbon refrigerants to carry out servicing or repairs which involve the removal of covers.

The room for installing the appliance must be at least 1m<sup>3</sup> per 8g of refrigerant. The amount and type of refrigerant in the appliance can be found in the technical specifications on page 17 and on the appliance rating plate.

# Product Overview

## WINE CHILLER LAYOUT



**KEY:**

- 1. Electronic Control Panel
- 2. Hinge Cover
- 3. Glass Door
- 4. Recessed Handle (on both sides)
- 5. Timber Shelves (5) + Timber Rack (1)
- 6. Security Lock (centred beneath glass door)
- 7. Levelling Legs (4)
- 8. Keys for lock (not shown)

## CONTROL PANEL LAYOUT

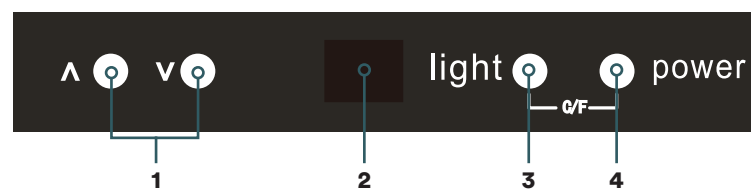

**KEY:**

- 1. Temperature “^” & “v” Controls  
Press the Up or Down buttons to increase or decrease the temperature inside the wine chiller cabinet in 1°C intervals.
- 2. LED Display  
Displays the current temperature inside the wine chiller cabinet.
- 3. Light Control Button  
Press the light control button to turn the interior light ON and OFF.
- 4. Power Control Button  
Press the power button to turn the wine chiller ON and OFF.

**Note:**

- **Temperature Units**  
Press and hold the Light and Power button together for 5 seconds to change the temperature display units from Celsius to Fahrenheit

---

# Getting Started

## UNPACKING

- **Packaging materials:** This wine chiller has been packaged to protect it against transportation damage. Remove all packaging materials from around and inside the wine chiller and keep the original packaging carton and materials in a safe place. It will help prevent any damage if the product needs to be transported in the future, and you can use it to store the wine chiller when it is not in use. In the event the carton is to be disposed of, please recycle all packaging materials where possible.
- **Suffocation:** Plastic wrapping can be a suffocation hazard for babies and young children, so ensure all packaging materials are out of their reach and disposed of safely.
- **Power cord:** Unwind the power cord to its full length and inspect it for damage. Do not use the wine chiller if it or its cord have been damaged or are not working properly. In case of damage, contact our after sales support line for advice on examination, repair or return of the damaged product.
- **Read the manual:** Read this manual to familiarise yourself with the wine chiller. Pay particular attention to the safety instructions on the previous pages.
- **Clean:** To remove any dust from transit and storage, clean the interior and exterior surfaces of the wine chiller with lukewarm water and a soft cloth. Dry thoroughly.

---

# Installation

- **Two person installation:** Use two or more suitably qualified people to move and install the wine chiller. Failure to do so can result in back or other injury.
- **Freestanding design:** This wine chiller is designed to be freestanding only, and should not be recessed or built-in.
- **Floor surface:** This wine chiller must be properly positioned on a dry, sturdy, level surface that is strong enough to support it when it is fully loaded.

Do NOT install/use the wine chiller in the following locations/situations:

- In a garage or any other outside installation.
  - In moist areas or areas of high humidity.
  - In a recreational vehicle, or for use with an inverter.
  - In direct sunlight, near heat sources, next to an open flame, cooking or heating appliance, or near any other source of high heat.
  - Direct sunlight may affect the acrylic coating and heat sources may increase the unit's power consumption. For best energy efficiency install the wine chiller in the coolest area of the room.
  - In an area with extreme cold ambient temperatures.
  - In an area with excessive moisture and high humidity. Make sure it is protected from elements such as wind, rain, water spray or drips.
  - In an area where petrol or other explosive and/or flammable liquids or fumes are used or stored. The fumes can create a fire hazard or explosion.
- 
- **Levelling:** It is important for the wine chiller to be level in order to work properly. To level the unit, adjust the levelling legs at the bottom of the wine chiller.
  - **Ventilation:** To allow for proper air ventilation, leave a minimum 5cm of space between the back, sides and top of the wine chiller and make sure that the front of the unit is completely unobstructed. Ensure that the ventilation openings are never blocked or covered. Never cover shelves with aluminium foil or any other material, which may prevent air circulation.
  - **Door swing:** The door on this appliance can be opened from either the left or the right side. Should you wish to change the door swing direction, follow the instructions on pages 16–17.

---

## Installation (Cont...)

- Suggested ambient temperatures: Choose a well ventilated area for the wine chiller with temperatures above 16°C and below 32°C. Ambient temperatures above or below this range may affect the performance of the unit.
- Settling: Before connecting the wine chiller to the power source, let it stand upright for approximately 4 hours. This will allow any refrigerant gasses that may have been disturbed during the transportation process to settle and reduce the possibility of a malfunction in the cooling system from handling during transport.
- Electrical connection: Plug the wine chiller into a dedicated, properly installed wall outlet. Do not under any circumstances cut or remove the third (earth) prong from the power cord. Any questions concerning power and/or earthing should be directed toward a licensed electrician or our after sales support centre.
- After plugging the wine chiller in, turn the unit on and allow it to cool down for 3–4 hours before placing wine bottles or beverages in the appliance.

---

## Operation

### FIRST USE

- Powering on: Press and hold the POWER button for three seconds to turn the appliance on.
- First cooling down: When you first switch on the wine chiller, the compressor will run continuously until the wine chiller reaches the set temperature. During this period of time, try not to open the door frequently or place bottles inside the appliance. After about 3–4 hours, you can start loading the wine chiller.
- Odour: You may notice an odour when you first switch on the wine chiller. This is due to the parts being new and is no cause for concern. The odour will subside as the wine chiller starts to cool.

### IMPORTANT

- When you use the wine chiller for the first time or restart it after it has been turned off for a long time, there could be a few degrees variance between the temperature you select and the one indicated on the LED display. This is normal and it is due to the length of activation time. Once the wine chiller has been running for a few hours, everything will return back to normal.
- When loading several bottles of wine at once, it will take longer for the appliance to cool the individual bottles than when adding a bottle at a time.
- If the unit is switched off or unplugged, you must allow at least 5 minutes before restarting the wine chiller or reconnecting it to your mains supply.

### TEMPERATURE CONTROL

This wine chiller enables you to store your wine in a stable temperature environment and free from light exposure and vibrations. These are most important factors when it comes to storing wine. A stable, temperature-appropriate environment will help maintain the quality of your wine and prevent spoilage.

- Selecting the right temperature: You can store your wine at the most appropriate serving temperature (see the table below). Set the temperature according to the type of wine that is mostly stored in the wine chiller.



WINE TYPE	RECOMMENDED STORAGE TEMPERATURE
Bordeaux Red	18°C
Burgundy / Bordeaux Red	16°C
Port	15°C
Young Burgundy Red	14°C
Young Red Wines / Rosé	12°C
Aged White Wines / Chardonnay	10°C
Sherry	7–9°C
Young White Wines	5–7°C

#### Setting and adjusting the temperature:

You can set and adjust the temperature in the cabinet to anywhere within the cooling range (5°C – 18°C).

1. To adjust the temperature, press the UP or DOWN button repeatedly.
2. With every press, the temperature will increase (or decrease) by one degree.
3. The current temperature inside the cabinet is shown on the LED display.
4. To view the set temperature at any time, press the UP or DOWN button and the set temperature will temporarily flash in the LED display for a few seconds.

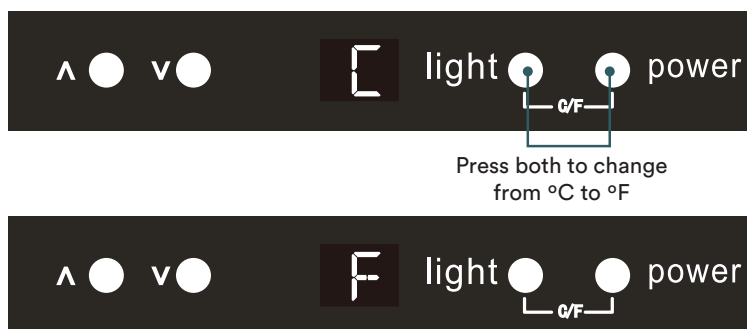

#### Temperature display:

The temperature inside the cabinet can be displayed in either degrees Celsius (°C) or degrees Fahrenheit (°F). The default setting is in °C.

To change the display to °F

1. Press and hold the LIGHT and POWER button together for approximately 5 seconds.
2. The temperature value will change and the °F indicator will be illuminated on the control panel.

# Operation (cont...)

## LOADING THE WINE CHILLER

**Standard bottle capacity:** Your wine chiller holds a maximum of 45 standard (traditional 750mL bottles). Do not overload the cabinet, and only store wine in sealed bottles.

**Larger bottles:** Storing wine in larger or different shaped bottles may affect its storage capacity. If storing larger bottles, make sure that they do not prevent the door from shutting properly. Before shutting the door, always check that you can close it without bottles falling down inside the cabinet.

**Shelving configuration:** The shelves in the wine chiller may be removed to suit various wine bottle shapes and sizes. The loading diagram (Fig. 1) shows how to fit the maximum amount of standard size and shape bottles. (See page 14 for instructions on how to remove a shelf)

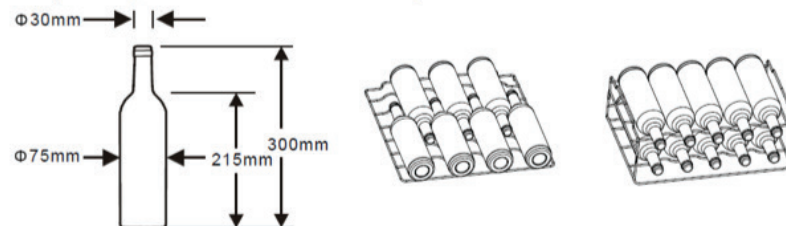

Fig. 1

**Access:** To prevent damaging the door gasket, make sure the door is fully open when pulling shelves out of the rail compartment. For easy access to the bottles stored, pull the shelves out approximately one third. The shelves are designed with an emergency stop to prevent them being removed too far when loaded.

**For efficient operation:** Do not open the door unnecessarily. Only keep it open for as long as necessary when removing or adding a bottle.

### Interior Light

- Your wine chiller has an LED interior light for your viewing convenience. To activate the light, press the LIGHT button on the control panel and check the contents, then press the button again to switch off the light.
- For best wine storage conditions, always leave the light off during normal operation.
- Note: If the light is not working or needs to be replaced, please call our After Sales Support on 1300 11 4357 for further guidance.

### Door Lock

- Your wine chiller is equipped with a lock and key for safe storage of wine.
- The keys are located inside the plastic bag that contains the instruction manual.
- Insert the key into the lock and turn it counter clockwise to unlock the door.
- Turn the lock clockwise to lock the door, making sure the metal pin is engaged completely
- Remove the key and place it in a secure place for safekeeping.

### Fridge Door Detector Alarm

- If the chiller door is accidentally left open for more than one and a half minutes, an audible alarm will sound. To stop the beeping, press any button on the controls or simply close the chiller door.

# Door Reversal

## LIST OF TOOLS TO BE PROVIDED BY THE USER



Cross screwdriver

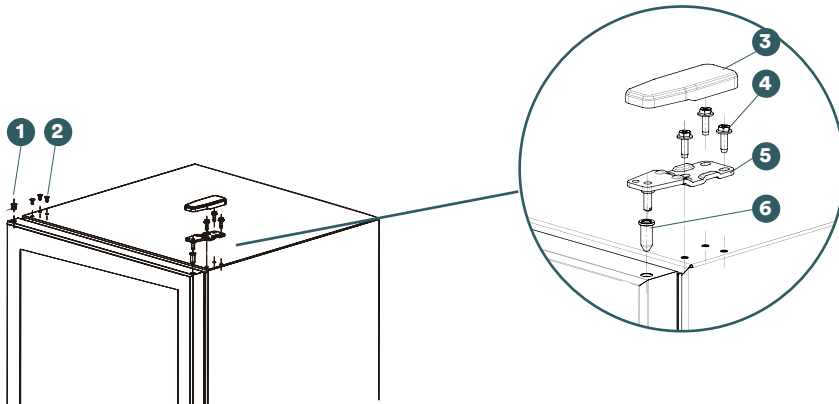

## ASSEMBLY STEPS

- a.** Change the installation location of the hinge **5** of the wine cooler, then the opening direction of the door could be changed at will. Please follow the following instructions for the change of the opening direction of the wine cooler's door (for instance: from right-handed door to left-handed door): close the glass door of the wine cooler, use a blade to remove the ornaments **1** and **2** carefully, loose the mounting cover **3** of the door hinge and three positioning bolts **4** and remove the upper hinge **5** and axle sleeve **6**.

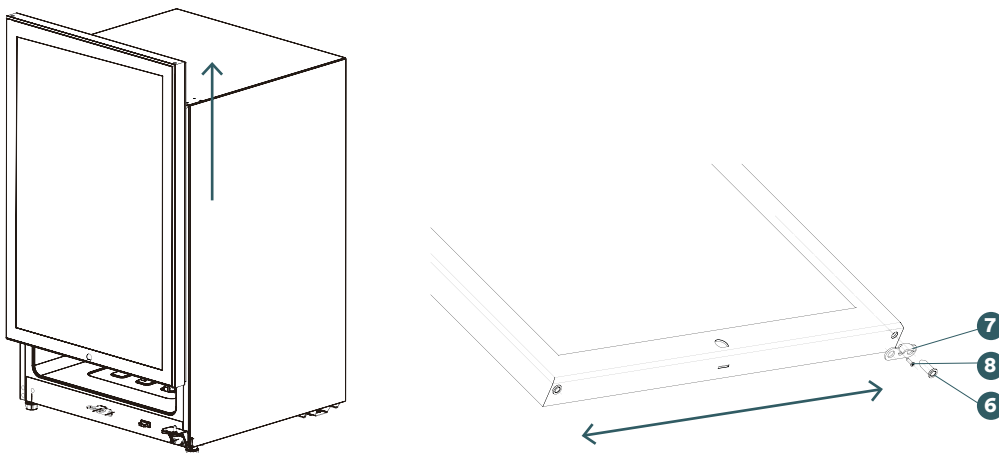

- b.** Open the door of the wine cooler and detach the glass door of which with tremendous care.  
**c.** Loose the door axle sleeve **6** at lower part of the glass door, door stopper block screws **8** and door stopper **7**, and fix them to left side.

# Door Reversal (cont...)

d. Dismantle the shaft 9 of upper hinge, and install it on left side.

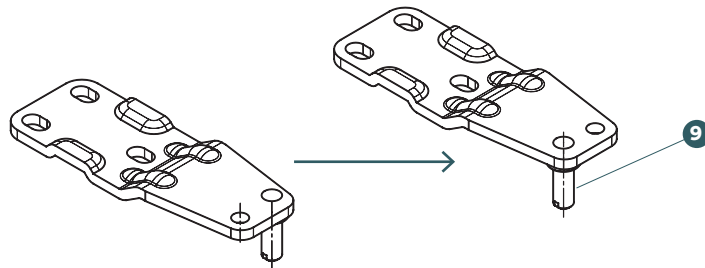

d. Dismantle the shaft 9 of upper hinge, and install it on left side.

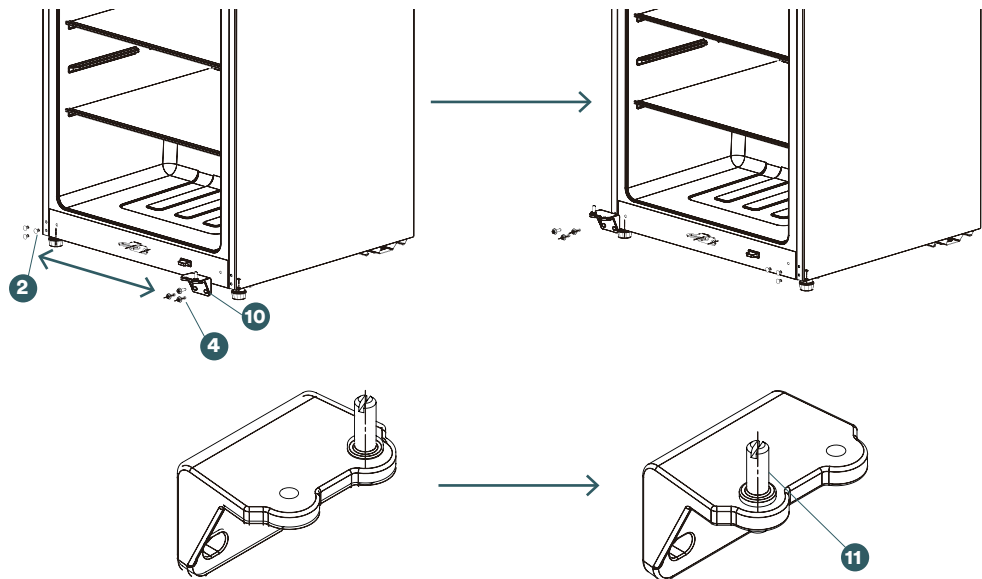

e. Use a blade to dismantle the ornaments 2 and loose the positioning bolts 4 and lower hinge 10, dismantle the shaft 11 of lower hinge, and install it on left side then exchange the parts of right and left sides and later use the reverse method to secure the lower hinge and ornaments

e. Re-install the aforesaid glass door to the lower hinge 10, install the door axle sleeve 6 back to upper left of glass door and refix the upper hinge 5. Align the door with the wine cooler and check the tightness of gasket, and then re-install all the ornaments 12.

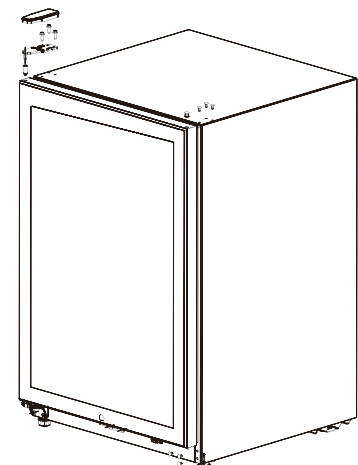

---

The page is  
intentionally  
left blank

# Maintenance and care of the appliance

## OVERALL CLEANING

Dust behind the refrigerator and clean the floor around the appliance to improve the cooling effect and energy efficiency. The interior of the refrigerator should be cleaned regularly to avoid odour. Soft towels or sponges dipped in water and non-corrosive neutral detergents are suggested for cleaning. The freezer should be cleaned with clean water and a cloth.



Do not use hard brushes, clean steel balls, wire brushes, abrasives, such as toothpastes, organic solvents (such as alcohol, acetone, banana oil, etc.), boiling water, acid or alkaline items clean refrigerator considering that this may damage the fridge surface and interior. Do not rinse with water so as not to affect the electrical insulation properties.

**WARNING:** Please unplug the refrigerator for defrost and cleaning.

## DEFROSTING

The refrigerator is made based on the air-cooling principle and thus has automatic defrosting function. Frost formed due to change of season or temperature may also be manually removed by disconnection of the appliance from power supply or by wiping with a dry towel.

## OUT OF OPERATION

**Power failure:** In case of power failure, even if it is in summer, foods inside the appliance can be kept for several hours; during the power failure, reduce the times the door is opened shall be reduced, and no more fresh food shall be put into the appliance.

Long-time nonuse: The appliance shall be unplugged and then cleaned; then the doors are left open to prevent odour.

**Moving:** Before the refrigerator is moved, remove all objects from inside, fix the glass partitions, vegetable holder, freezing chamber drawers and etc. with tape, and tighten the leveling feet; close the doors and seal them with tape. During moving, the appliance shall not be laid upside down or horizontally, or be vibrated; the incline during movement shall be no more than 45°.

The appliance shall run continuously once it is started. Generally, the operation of the appliance shall not be interrupted; or otherwise the service life may be impaired.

# Troubleshooting

PROBLEM	POSSIBLE CAUSES WHAT TO DO
Failed operation	<p>Check whether the appliance is connected to power or whether the plug is making good contact.</p> <p>Check whether the voltage is too low.</p> <p>Check whether there is a power failure or partial circuits have tripped</p>
Odour	<p>Odorous foods shall be tightly wrapped</p> <p>Check whether there is any rotten food</p> <p>Clean the inside of the refrigerator</p>
Long-time operation of the compressor	<p>Long operation of the refrigerator is normal in summer when the ambient temperature is high It is not recommended to have too much food in the appliance at the same time</p> <p>Food shall get cool before being put into the appliance</p> <p>The doors are opened too frequently</p>
Light fails	<p>Check whether the refrigerator is connected to power supply and whether the illuminating light is damaged</p>
Doors cannot be properly closed	<p>The door is stuck by food packages. Too much food is placed within the appliance. The refrigerator is tilted</p>
Loud noise	<p>Check whether the floor is level and whether the refrigerator is also level. Check whether accessories are placed at proper locations</p>
Door seal loose	<p>Remove foreign matters on the door seal</p> <p>Heat the door seal and then cool it for restoration (or blow it with an electrical drier or use a hot towel for heating)</p>
Water pan overflows	<p>There is too much food in the chamber or food stored contains too much water, resulting in heavy defrosting</p> <p>The doors are not closed properly, resulting in frosting due to entry of air and increased water due to defrosting</p>
Hot housing	<p>Heat dissipation of the built-in condenser via the housing, which is normal. When housing becomes hot due to high ambient temperature, storage of too much food or the compressor is shut down, provide sound ventilation to facilitate heat dissipation</p>
Surface condensation	<p>Condensation on the exterior surface and door seals of the refrigerator is normal when the ambient humidity is too high. Just wipe the moisture with a clean towel.</p>
Abnormal noise	<p><b>Buzz:</b> The compressor may produce buzzes during operation, and the buzzes are loud particularly upon start or stop. This is normal.</p> <p><b>Creak:</b> Refrigerant flowing inside of the appliance may produce creak, which is normal.</p>

---

# Specifications

<b>Product Dimensions (W, D, H):</b>	545mm, 565mm, 855mm
<b>Weight:</b>	36kg
<b>Temperature Range:</b>	5–18°C
<b>Other Features:</b>	White internal LED light
	Electronic controls
	Double layer UV glass

## STANDARDS

This product complies with AS/NZS 60335.1 and AS/NZS 60335.2.24 electrical safety, and with EN 55014-1:2006+A1:2009 A2:2011 for electromagnetic compatibility.



Attach your receipt  
to this page



## Purchase Details

---

For future reference, please record the following information  
which can be found on the rating plate and the date of purchase  
which can be found on your sales invoice.

---

### STORE DETAILS

STORE NAME | \_\_\_\_\_

ADDRESS | \_\_\_\_\_

TELEPHONE | \_\_\_\_\_

PURCHASE DATE | \_\_\_\_\_

---

### PRODUCT DETAILS

MODEL NO. | \_\_\_\_\_

SERIAL NO.\* | \_\_\_\_\_

# Warranty Information

---

## WARRANTY TERMS & CONDITIONS REFRIGERATION APPLIANCES

This document sets out the terms and conditions of the product warranties for Residentia Group Appliances. It is an important document. Please keep it with your proof of purchase documents in a safe place for future reference should you require service for your Appliance.

1. **IN THIS WARRANTY**
  - (a) 'acceptable quality' as referred to in clause 10 of this warranty has the same meaning referred to in the ACL;
  - (b) 'ACL' means Trade Practices Amendment (Australian Consumer Law) Act (No.2) 2010;
  - (c) 'Appliance' means any Residentia Group product purchased by you accompanied by this document;
  - (d) 'ASR' means Residentia Group authorised service representative;
  - (e) 'Residentia Group' means Residentia Group Pty Ltd of 165 Barkly Avenue, Burnley VIC 3121, ACN 600 546 656 in respect of Appliances purchased in Australia;
  - (f) 'major failure' as referred to in clause 10 of this warranty has the same meaning referred to in the ACL and includes a situation when an Appliance cannot be repaired or it is uneconomic for Residentia Group, at its discretion, to repair an Appliance during the Warranty Period;
  - (g) 'Warranty Period' means:
    - (i) where the Appliance is used for personal, domestic or household use (i.e. normal single family use) as set out in the instruction manual, the Appliance is warranted against manufacturing defects for 24 months, following the date of original purchase of the Appliance;
  - (h) 'you' means the purchaser of the Appliance not having purchased the Appliance for re-sale, and 'your' has a corresponding meaning.
2. This warranty only applies to Appliances purchased and used in Australia and is in addition to (and does not exclude, restrict, or modify in any way) any non-excludable statutory warranties in Australia.
3. During the Warranty Period Residentia Group or its ASR will, at no extra charge if your Appliance is readily accessible for service, without special equipment and subject to these terms and conditions, repair or replace any parts which it considers to be defective. Residentia Group or its ASR may use remanufactured parts to repair your Appliance. You agree that any replaced Appliances or parts become the property of Residentia Group. This warranty does not apply to light globes, batteries, filters or similar perishable parts.
4. Parts and Appliances not supplied by Residentia Group are not covered by this warranty.

- 
5. You will bear the cost of transportation, travel and delivery of the Appliance to and from Residentia Group or its ASR. If you reside outside of the service area, you will bear the cost of:
- travel of an authorised representative;
  - transportation and delivery of the Appliance to and from Residentia Group or its ASR, in all instances, unless the Appliance is transported by Residentia Group or its ASR, the Appliance is transported at the owner's cost and risk while in transit to and from Residentia Group or its ASR.
6. Proof of purchase is required before you can make a claim under this warranty.
7. You may not make a claim under this warranty unless the defect claimed is due to faulty or defective parts or workmanship. Residentia Group is not liable in the following situations (which are not exhaustive):
- the Appliance is damaged by:
    - accident
    - misuse or abuse, including failure to properly maintain or service
    - normal wear and tear
    - power surges, electrical storm damage or incorrect power supply
    - incomplete or improper installation
    - incorrect, improper or inappropriate operation
    - insect or vermin infestation
    - failure to comply with any additional instructions supplied with the Appliance;
  - the Appliance is modified without authority from Residentia Group in writing;
  - the Appliance's serial number or warranty seal has been removed or defaced;
  - the Appliance was serviced or repaired by anyone other than Residentia Group, an authorised repairer or ASR.
8. This warranty, the contract to which it relates and the relationship between you and Residentia Group are governed by the law applicable where the Appliance was purchased.
9. To the extent permitted by law, Residentia Group excludes all warranties and liabilities (other than as contained in this document) including liability for any loss or damage whether direct or indirect arising from your purchase, use or non use of the Appliance.
10. For Appliances and services provided by Residentia Group in Australia, the Appliances come with a guarantee by Residentia Group that cannot be excluded under the Australian Consumer Law. You are entitled to a replacement or refund for a major failure and for compensation for any other reasonably foreseeable loss or damage. You are also entitled to have the Appliance repaired or replaced if the Appliance fails to be of acceptable quality and the failure does not amount to a major failure. The benefits to you given by this warranty are in addition to your other rights and remedies under a law in relation to the Appliances or services to which the warranty relates.
11. At all times during the Warranty Period, Residentia Group shall, at its discretion, determine whether repair, replacement or refund will apply if an Appliance has a valid warranty claim applicable to it.
12. To enquire about claiming under this warranty, please follow these steps:
- carefully check the operating instructions, user manual and the terms of this warranty;
  - have the model and serial number of the Appliance available;
  - have the proof of purchase (e.g. an invoice) available;
  - telephone the numbers shown below.
13. You accept that if you make a warranty claim, Residentia Group and its ASR may exchange information in relation to you to enable Residentia Group to meet its obligations under this warranty.

#### IMPORTANT

Before calling for service, please ensure that the steps in point 12 have been followed.

Telephone contact

→ Service: Please call 1300 11 HELP (4357)

---

The Australian Consumer Law requires the inclusion of the following statement with this warranty:

Our goods come with guarantees that cannot be excluded under the Australian Consumer Law. You are entitled to a replacement or refund for a major failure and for compensation for any other reasonably foreseeable loss or damage. You are also entitled to have the goods repaired or replaced if the goods fail to be of acceptable quality and the failure does not amount to a major failure.

AN INITIATIVE BY

RESIDENTIA GROUP

# INALT<sup>®</sup> CLASSIQUE



E2447

TEL. 1300 11 4357  
SUPPORT@RESIDENTIAGROUP.COM.AU  
WWW.RESIDENTIA.GROUP